

180 Series

Mass Flow Controller/Meter for Low to Medium Flow (5 sccm—30 slm) with Elastomer Seals

- » Outstanding reliability and repeatability
- » 1% full scale accuracy
- » Accepts ± 15 VDC or 11–33 VDC single ended power options



Features at a glance

- MTBF of over 500,000 hours
- Repeatability $\pm 0.15\%$ of full scale
- Less than 1 second response
- Range 5 sccm—30 slm (N_2 equivalent)
- Control signal: 0-5 VDC
- Zero drift: $< 0.6\%$ per year
- 1×10^{-9} atm-cc/sec (He)
- 316L stainless steel or aluminum block
- 2 year warranty
- Worldwide service
- Standard 1% full scale accuracy

Performance

Celerity's Unit 180 Series is the most advanced mini mass flow controller and meter (MFC/MFM). The Unit 180 Series is based on the proven designs developed by Celerity for the most demanding process control applications. The accuracy and repeatability of Unit mass flow instruments increases yields and output quality.

Typical applications

- Non-corrosive, non-reactive gases
- Analytical equipment
- Environmental gas monitoring and control
- Medical gas delivery and monitoring
- General process control
- Laser systems
- Fiber optics and glass coating
- Vacuum processes
- Combustion control
- Leak testing
- Gas sampling
- Carrier gas monitoring
- Central gas distribution
- Orifice sizing
- Particulate sampling
- Gas chromatography
- Tank blanketing
- Bioreactor gas management
- Flame control
- Mixing / Blending
- Thin films
- Argon flow for electro-surgery
- Chemical and petrochemical gas analysis
- Pharmaceutical manufacturing
- Aerospace

Product dimensions

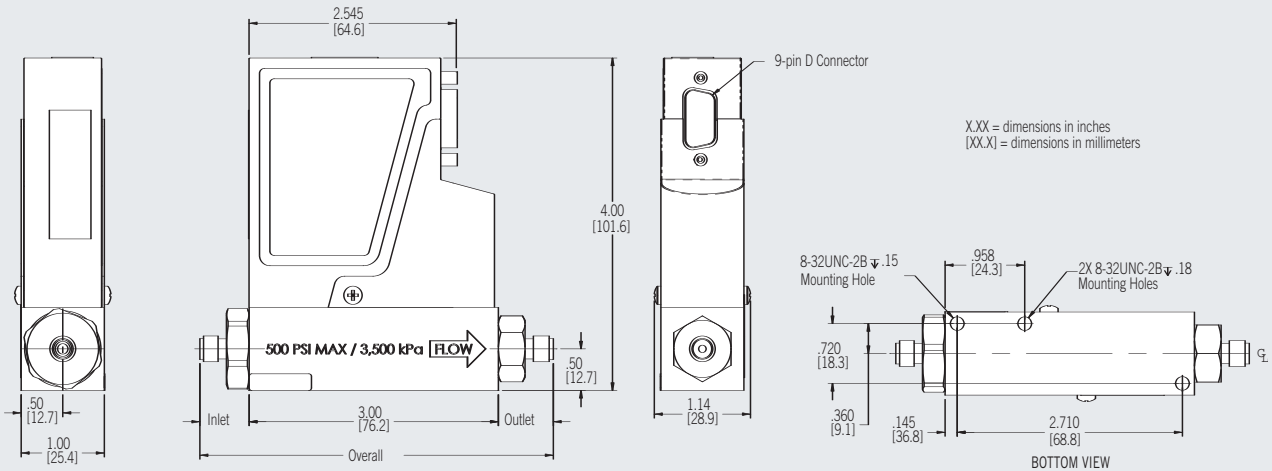

Advanced design

The design of the mass flow controller integrates the sensor, valve, and electronics into a single compact device. It is designed for applications requiring a small footprint with high accuracy, repeatability and low maintenance. Further, the 180 Series is designed using sophisticated modeling techniques to maximize output and minimize noise. Communications is plug-and-play. The controller automatically recognizes if power is ± 15 VDC or 11–33 VDC.

Unmatched repeatability

Repeatability is unmatched in Unit flow instruments. The features that provide our superior repeatability are the sensor, the unique frictionless free floating solenoid control valve, and superior control electronics with temperature compensation. The Unit 180 Series provides the same process result within 0.15% time after time, exceeding industry standards for repeatability.

Tested and field-proven reliability

Reliability is designed into the 180 Series in a variety of ways. The electronics provide easier calibration, low drift and linear accuracy. The stable sensor allows for just 0.6% drift over a year exceeding the performance of any mass flow controller or meter in its class. After millions of cycles, the Unit valve shows no signs of performance degradation.

Precision electromagnetic valve

The Unit 132 valve technology incorporated into the 180 Series is the premier proportional control valve technology on the market today. Its 1000:1 turn-down resolution provides superior precision and control. The unique design has been optimized to eliminate threads and shims that can trap dirt and moisture. In testing, it has been subjected to over 8 million cycles with no degradation in performance. The electromagnetic actuator has been proven to have superior reliability to Piezo actuators and can also operate over a larger pressure range. This design has been used in over 100,000 precision mass flow controllers demonstrating unmatched reliability.

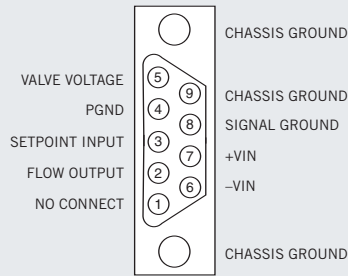

Fitting type	Overall	Inlet	Outlet
1/8" SW male	4.32 in./109.7 mm	0.66 in./16.8 mm	0.66 in./16.8 mm
1/4" SW male	4.44 in./112.8 mm	0.72 in./18.3 mm	0.72 in./18.3 mm
1/4" VCO male	4.56 in./115.8 mm	0.78 in./19.8 mm	0.78 in./19.8 mm
1/4" VCR male	4.88 in./124.0 mm	0.94 in./23.9 mm	0.94 in./23.9 mm
3/8" SW male	4.50 in./114.3 mm	0.72 in./18.3 mm	0.78 in./19.8 mm

180 Series product dimensions

CrossChek™ metrology system



Celerity's world-class CrossChek calibration methodology maintains SPC-verified calibration accuracy within ± 3 sigma limits (99.7% confidence level).

CrossChek calibration methodology provides ongoing verification of production calibration standards. This ensures consistent and repeatable accuracy performance within ± 3 sigma of published specifications. No other flow control company offers the same guarantee.

Superior manufacturing capabilities



Celerity is an ISO 9001 registered company. All manufacturing processes are rigorously qualified in the development process. All specifications are certified based on statistically significant samples. Celerity utilizes a world-class metrology laboratory which is one of only a handful of gravimetric measurement facilities in the United States.

Warranty

- 2 year standard warranty
- Extended warranty option available

180 Series High Performance Mass Flow Controllers/Meters

Product specifications

Flow range	5 sccm to 30 slm (N ₂ equivalent)
Accuracy	$\pm 1\%$ full scale ($\pm 3\sigma$)
Repeatability	$\pm 0.15\%$ full scale
Turn down ratio	50:1
Linearity	$\pm 0.15\%$ full scale
Operating pressure:	
Maximum inlet pressure	500 psig
Proof pressure	1,500 psig
Pressure drop (controller)	7 to 40 psid
Pressure drop (meter)	< 4 torr (0.08 psid)
Response time:	
Fast	< 1 second
Standard	3–5 seconds
Operating temperature	0 to 50°C
Temperature coefficient:	
Zero	$\pm 0.03\%$ full scale per °C
Span	$\pm 0.05\%$ full scale per °C
Pressure coefficient	0.0025% per psi
Zero drift	< 0.60 % per year without auto-zero
Leak integrity	1x10 ⁻⁹ atm-cc/sec (He)
Warm-up period	30 minutes

180 Analog	
Power input	11–33 Vdc
Control signal	0–5 Vdc
Max. power controller	3.6 W
Max. power meter	1 W

Electrical connection	9 pin "D" type connector
Input impedance	100,000 ohm minimum
Output impedance	10 ohm maximum
Wetted materials	316L stainless steel, elastomer seal, 304 stainless steel spring
EMI/EFI resistance:	
Certification	Fully CE certified
Calibration	National Institute of Standards and Technology (N.I.S.T.) traceable

Specifications and features are subject to change without notice.

All specifications reflect nitrogen calibration using Molbloc/Molbox™ transfer standards.

Calibration by primary standards and surrogate gases is available as an additional charge option.

180 Series Mass Flow Controller/Meter

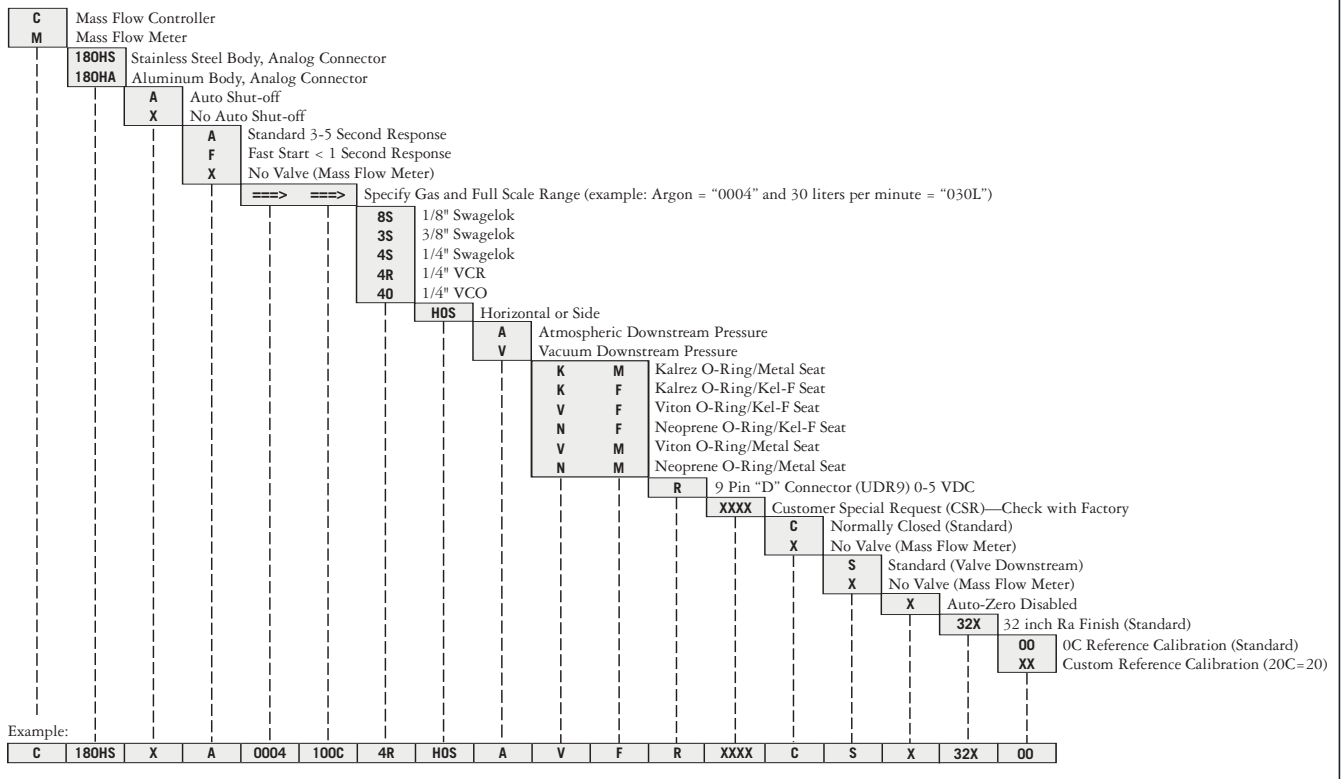

24/7 service and support

Celerity is unmatched in the industry for service and support. We have worldwide service locations with calibration, application support, and repair capabilities, operating 24 hours a day, 7 days a week. Celerity's website also provides updated application and technical support.

Visit us at www.celerity.net.



CELERITY, INC.
 22600 Savi Ranch Parkway
 Yorba Linda, California 92887
 Telephone 714.279.3500
 Facsimile 714.921.0804
www.celerity.net



For technical assistance, contact Celerity Applications Engineering at 714.279.3500.



Celerity, Unit, MultiFlo, IsoSensor, and CrossChek are trademarks of Celerity, Inc. All other product or service names mentioned in this document may be trademarks of the companies with which they are associated. System descriptions are typical and subject to change without notice.